

Data-Driven Optimization of Urban Traffic using AI and Real-Time Analysis

Taiba SAYED MANSOR^{*1}, Rayan ABRI^{*2}

^{*} Computer Engineering, Ostim Technical University, Turkey

² (rayan.abri@ostimteknik.edu.tr)

Abstract – Optimizing urban traffic is a significant problem for cities all over the world. This research aims to tackle this issue by utilizing real-time analysis and artificial intelligence (AI). The project's key components are data collection, the creation of a 2D map, object detection using the YOLO algorithm, 3D segmentation, visualization, and data integration. To ensure the precision of data collection, we employ a multi-GNSS RTK approach for precise location determination. This method allows us to generate exact coordinates for urban road networks, which provides the basis for additional research. We are able to display urban traffic flows on a 2D visualization map, allowing us to spot crowded locations and improve traffic flow. The YOLO method is used in conjunction with 3D segmentation to identify objects. Through training, we allow this algorithm to recognize and categorize a wide range of objects, including moving vehicles, pedestrians, and particular vehicle types (such as minibusses and taxis), which significantly contribute to traffic congestion. Our project makes better use of real-time object detection to enable well-informed decision-making and improve understanding of the traffic situation.

Keywords – Data Acquisition, 2D Map Creation, Object Recognition Using The YOLO Algorithm With 3D Segmentation, Visualization, And Data Integration.

I. INTRODUCTION

Cities all around the world struggle with the serious problem of urban traffic congestion. It causes longer commutes, more air pollution, and less effective transportation systems overall. Innovative strategies utilizing data-driven methodologies and cutting-edge technologies are needed to address this dilemma. With an emphasis on data collection, 2D map generation, object detection, visualization, and data integration, this project seeks to enhance urban traffic using real-time analysis and artificial intelligence (AI). The 2D map's visual representation of object detections provides an in-depth description of the traffic situation. Authorities and researchers can gain important information about traffic patterns and congested areas by overlaying detected objects on a

map. This image helps in understanding pedestrian movement, analyzing traffic flow, and locating densely populated locations. By creating a centralized data pool that enables seamless integration and analysis, it is possible to manage and analyze the obtained data efficiently. Researchers and urban planners may acquire a full dataset for additional analysis, optimization, and decision-making by combining the data collected from object detection with other relevant data sources. The project's findings significantly advance both scientific understanding and local urban area optimization. Numerous uses are made possible by the data acquired, including the study of traffic flow, assessment of density, categorization of vehicles, detection of traffic infractions, and identification of traffic events. The initiative offers useful insights to manage urban traffic and improve the overall

transportation system by leveraging the power of AI algorithms and real-time data analysis. In order to overcome the difficulties of urban traffic, this data-driven optimization effort makes use of AI and real-time analysis. The project delivers useful insights for scientific study and regional urban area optimization through accurate data gathering, 2D map generation, item detection, visualization, and data integration. The project's results help in the study of traffic patterns and the creation of plans for decongesting traffic and enhancing the effectiveness of transportation. Urban traffic planning has a chance to be revolutionized thanks to the exponential increase in data availability and improvements in AI algorithms. This research uses AI to mine the massive volumes of data gathered from numerous sources, including GPS, cameras, and other sensors, to uncover insightful information. These insights will allow for better knowledge and study of traffic patterns, congested locations, and causes leading to traffic difficulties.

The project starts with data collection, where exact position determination is critical. Accurate and high-resolution position data may be produced using techniques such as multi-GNSS RTK (Real-Time Kinematic). This data forms the basis for later investigations, allowing for the exact mapping of urban road networks and the identification of essential traffic locations. Developing a 2D visualization map is critical for acquiring a thorough picture of traffic patterns and congestion. Authorities and academics may detect high-density regions, traffic bottlenecks, and other critical elements influencing traffic efficiency by showing the collected data on a map. This graphic supports the creation of efficient traffic flow optimization and congestion reduction techniques.

The research utilizes advanced object recognition algorithms to improve the accuracy of traffic analyses. The YOLO method, when paired with 3D segmentation, detects and classifies a wide range of objects, including automobiles, people, and particular vehicle types (e.g., minibusses and taxis). The project can better evaluate traffic patterns, predict traffic volumes, and comprehend interactions between diverse road users by precisely recognizing and tracking these items. Visualization

is critical in making sense of the acquired data. Authorities and academics can acquire significant insights into the spatial distribution of traffic and possible congestion hotspots by overlaying item detections on the 2D map. This visualization supports traffic management and infrastructure development decision-making processes.

In addition, data integration is essential for gaining a comprehensive picture of urban traffic dynamics. A complete data repository is created by combining data from several sources, such as item detections, GPS data, and other pertinent information. This integrated data enables more in-depth analysis, allowing academics and urban planners to find complicated correlations, get significant insights, and design successful traffic optimization plans.

The project's findings have the potential to further scientific study on urban traffic optimization and help in local urban area planning. The data-driven strategy, combined with artificial intelligence tools and real-time analysis, provides a formidable foundation for tackling traffic congestion and boosting transportation efficiency. This initiative intends to pave the way for better, more effective urban traffic management by leveraging sophisticated technology and big data insights.

II. LITERATURE SURVEY

The escalating issue of urban traffic congestion has spurred researchers to explore data-driven strategies that harness real-time analysis and artificial intelligence (AI) to enhance traffic flow. This literature review aims to examine the current state of research and diverse methodologies employed in the data-driven optimization of urban traffic, specifically focusing on the utilization of AI and real-time analysis.

The usefulness of data-driven techniques in anticipating and controlling traffic congestion has been shown in this field of study. A model for predicting urban transportation congestion patterns based on data was put out by Jia et al. The study accurately predicted congestion patterns using

previous traffic data and machine learning techniques, enabling better traffic management decisions. A similar multi-agent, data-driven, distributed adaptive cooperative control system for urban traffic signal timing was presented by Zhang et al. [2]. Their method enhanced traffic flow and decreased delays through real-time signal timing optimization utilizing traffic data.

Lei, Hou, and Ren [3] devised a data-driven, model-free adaptive perimeter control system to meet the complexity of urban traffic networks. Their method dynamically modified traffic signal timings throughout several areas of the city, significantly reducing congestion, by using real-time traffic data and taking route preferences into account. Different research by Najafi Moghaddam Gilani et al. [4] concentrated on data-driven analysis and forecasting of urban traffic accidents. The researchers discovered accident trends and forecasted accident occurrences using logit and machine learning-based pattern recognition models, providing helpful insights for preventative traffic safety measures.

In addition to traffic management, data-driven analysis has also been applied to other aspects of urban transportation. Bhatia et al. [5] explored the use of software-defined networking (SDN) for real-time urban traffic analysis in a vehicular ad-hoc network (VANET) environment. Their research demonstrated the potential of SDN for efficiently collecting and analyzing traffic data, enabling more effective decision-making in urban traffic management systems. Allen [6] discussed the broader implications of connected and networked driving, emphasizing the role of smart mobility technologies and big data-driven algorithmic decision-making in shaping urban transportation systems.

The utilization of large-scale data sets has been instrumental in understanding and predicting traffic flow dynamics. Lu, Sun, and Qu [7] developed a big data-driven approach for real-time traffic flow state identification and prediction. By harnessing the power of big data analytics, the study accurately identified and predicted traffic conditions, facilitating prompt responses and congestion mitigation. Yo Rafique et al. [8] focused on optimizing real-time parking management using

deep learning techniques. Their framework leveraged real-time data to improve parking availability and reduce search time by efficiently allocating parking spaces.

Research efforts on real-time data-driven transportation analysis and optimization have been sparked by the idea of smart cities. A framework for modeling real-time data-driven mobility in smart cities was created by Saroj et al. [9]. The study showed the potential of real-time data in modeling and optimizing transportation systems, eventually improving urban mobility, by combining real-time data sources with advanced simulation methodologies. Urban bus schedules were optimized by Tang et al. [10] using a multi-objective evolutionary algorithm in a data-driven manner. Their study emphasized the need to taking into account journey time dependability and passenger demand trends in order to schedule buses effectively.

Although the data-driven optimization of urban traffic is the main emphasis of this literature analysis, it is crucial to recognize other study fields that are equally relevant and offer insightful information. He, Liu, and Shen [11] explored business analytics-based smart urban logistics and transportation, underscoring the potential of data-driven decision-making for streamlining several facets of urban transportation systems. Subburaj et al.'s study [12] on the use of traffic-sensitive routing for effective garbage collection is remarkable. The authors provide a routing algorithm that takes advantage of changing traffic patterns and optimizes garbage collection routes by taking current traffic circumstances into account. Their research shows how dynamic traffic data may be incorporated into waste management systems to increase operational effectiveness and reduce environmental impact.

Another key component of traffic efficiency is the recognition of cars in urban settings. YOLOv7-RAR is a cutting-edge vehicle identification system that was created especially for urban environments, according to Zhang et al. [13]. Their method exhibits great efficacy and accuracy in identifying automobiles in real-time circumstances by utilizing deep learning techniques. This study demonstrates the potential of AI-based vehicle identification

methods, which can be useful in creating intelligent traffic control systems.

Zhang et al. [14] investigate the use of vehicle trajectory data mining in the context of real-time traffic information extraction. In order to provide accurate and current traffic statistics, their work focuses on utilizing AI algorithms to extract insightful information from vehicle trajectory data. The results underline how crucial it is to apply cutting-edge data mining tools for real-time traffic analysis, allowing effective traffic management and congestion alleviation.

A complete research paper on a real-time traffic light control system is presented by Mirchandani and Head [15]. Their investigation includes the design, computation, and analysis of a traffic light control system intended to enhance traffic flow. Their solution exhibits the capacity to react to changing traffic circumstances by utilizing clever algorithms, which reduce congestion and boost traffic efficiency. The design and implementation of real-time traffic signal control systems are discussed in useful detail in this work.

In addition, Shinde et al.'s study [16] on traffic optimization methods in optical networks for real-time traffic analysis. Their research focuses on using optimization techniques in optical networks to improve traffic analysis capabilities. The authors show the possibility of effective real-time traffic analysis, which can help with better traffic management in metropolitan areas, through the use of these algorithms.

In conclusion, the literature study shows that real-time analysis, AI, and data-driven approaches are becoming more and more popular for optimizing urban traffic. The research covered in this area demonstrates the potential for using real-time traffic data, cutting-edge algorithms, and technology, as well as improving signal timings, to improve traffic flow, ease congestion, and boost overall transportation efficiency. These works act as useful starting points for the investigation and creation of data-driven solutions.

A control algorithm for signal traffic optimization inside an urban traffic framework is proposed by Sadiqa and Yung-Cheol [17] in a

different setting. With a variety of criteria, including traffic volume and congestion patterns, their study tries to optimize signal timing and phasing. The study emphasizes the role of control algorithms in strengthening urban traffic networks' overall efficiency by minimizing delays and increasing traffic flow.

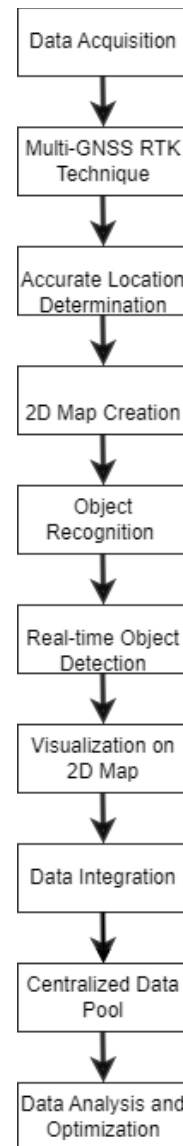

Fig.1 Basic workflow diagram

III. IMPLEMENTATION

Improving municipal traffic by using an artificial intelligence-based system

- Acquiring an exact position of the area to take pictures (RTK)
- Visualizing the area in two dimensions using the acquired map position

- Training the minibus, taxi, bicycle, and other vehicle models using the 3D segmentation method of the YOLO algorithm
- Displaying this data on the created 2D map and adding it to the data pool

A. *Data gathering and accurate location determination.*

Getting the information needed to optimize traffic is the first step. Getting photos or videos of the target location is necessary for this. Using kinematic (RTK) technology, precise position coordinates are obtained to guarantee accurate location information

Real-Time Kinematic, or RTK, is a positioning method used in surveying, mapping, and navigation applications to produce extremely exact and accurate location coordinates. It is frequently employed in circumstances where centimeter-level accuracy is necessary, such as in land surveying, precision farming, and self-driving car navigation.

A base station and a rover receiver are used in RTK. The base station is installed at an established reference site with established coordinates. Global Navigation Satellite Systems (GNSS), including GPS, GLONASS, and Galileo, send signals to it continuously. The phase and timing of these signals are carefully measured by the base station.

The same GNSS satellites also provide signals to the rover receiver, which is situated at the required location. However, a number of error factors, like air delays and satellite clock problems, have an impact on the measurements made by the rover receiver. The base station instantly provides correction data to the rover in order to correct its position. The discrepancies between the measurements taken by the base station make up this corrective data.

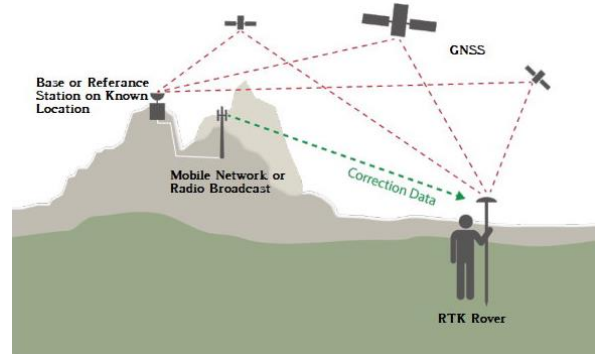

Fig. 2 GNSS RTK System

B. *Creation of a 2D Visualization Map*

A two-dimensional visual depiction of the selected region is created using the exact geographic coordinates acquired in step A. For further analysis and optimization procedures, this visual map serves as the starting point.

C. *Training the YOLO Algorithm with 3D Segmentation Technique*

In this step, a 3D segmentation technique is used to train the YOLO (You Only Look Once) algorithm. The algorithm has been trained to recognize and categorize various items, including cars, pedestrians, and particular car models (such as minibusses, taxis, bicycles, etc.). In order for the algorithm to effectively learn and detect these items, it must be fed with a sizable dataset of annotated photos or videos during the training process.

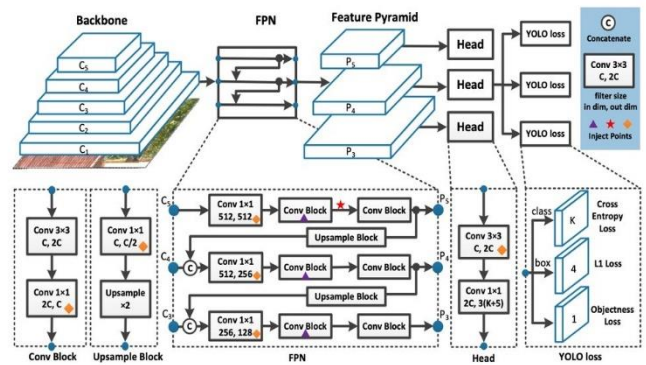

Fig. 3. The evolution of layer aggregation strategies in YOLOv7



Fig. 4. Object classification

D. Visualization and Data Integration

After training the YOLO algorithm, the next step is to display the results on the B-2D map. The identified objects, like cars and pedestrians, are shown and superimposed on the map. This perception gives a reasonable portrayal of the traffic situation nearby.

E. Data Pooling and Integration

The envisioned information, along with other pertinent data, is gathered and put away in an information pool or data set. Further analysis and optimization are made possible by this data pool, which serves as a centralized repository for traffic-related information.

The system can effectively use advanced computer vision techniques, object recognition algorithms, and data analysis to optimize municipal traffic if these steps are followed. The logical methodology guarantees that each step depends on solid techniques and produces precise outcomes for traffic streamlining purposes.

IV. RESULTS AND ANALYSE

This should explore the significance of the results of the work, not repeat them. The results should be drawn together, compared with prior work and/or theory, and interpreted to present a clear step forward in scientific understanding. Combined Results and Discussion sections comprising a list of results and individual interpretations in isolation are particularly discouraged.

A. Data Acquisition Method

The described project emphasizes the use of precise location determination (such as RTK) to capture images or video footage of the target area. This approach ensures accurate geospatial information for analysis. In contrast, existing systems might rely on different data sources, such as fixed traffic sensors, CCTV cameras, or vehicle tracking systems.

B. AI-Based Object Recognition

By combining the YOLO method with 3D segmentation, the project trains the system for object detection, including the classification of cars and pedestrians. This state-of-the-art computer vision technique enables the real-time identification and tracking of numerous objects. On the other hand, current systems may rely on predetermined rules or simpler algorithms for object identification and classification.

C. Visualization and Integration

The described project emphasizes the use of precise location determination (such as RTK) to capture images or video footage of the target area. This approach ensures accurate geospatial information for analysis. In contrast, existing systems might rely on different data sources, such as fixed traffic sensors, CCTV cameras, or vehicle tracking systems.

D. Potential Scope of Optimization

The fact that the project focuses on traffic optimization suggests that it can be used for more than just data collection and monitoring. Traffic flow will be improved, congestion will be reduced, safety will be increased, and possibly regional urban area optimization projects will benefit from the data. Research, real-time traffic control, short-term traffic management, and long-term planning are all possible applications of the current technologies.

V. CONCLUSION & FUTURE WORK

A system similar to the one presented can deliver a variety of data types that can be beneficial for further scientific research and local urban area optimization. The data that can be obtained includes, for instance.

Traffic Flow and Density: The system is able to provide data on the flow of traffic, including the

speed, direction, and density of the moving vehicles. The analysis of the traffic patterns as a whole and the location of bottlenecks or crowded regions can be aided by this data.

Pedestrian Movement: The system is able to identify and monitor pedestrians, providing information on their patterns of movement, concentrations of people, and potentially dangerous situations like congested sidewalks or pedestrian crossings.

Vehicle Classification: The system can offer information on the distribution of vehicles in a specific area by teaching the algorithm to identify various vehicle models (such as minibusses, taxis, and bicycles). Understanding how different modes of transportation are used and identifying particular vehicle types that exacerbate traffic congestion can benefit from this knowledge.

Traffic Infractions: The system can be taught to recognize and monitor traffic infractions, including running red lights or unauthorized parking. This information can be utilized for enforcing laws, locating regions with a high prevalence of violations, or even creating interventions to increase compliance.

Traffic Incident Detection: The system has the ability to automatically identify and alert authorities to traffic-related occurrences like accidents or other road dangers. To respond quickly and manage such crises effectively, this information may be essential.

Historical Data: The system is able to create a historical database by consistently gathering and archiving the displayed data over time. Long-term analysis, trend detection, and comprehension of the effects of many factors on traffic patterns and urban mobility may all be done with the use of this data.

The availability of such data can be an important tool for future scientific studies, city planning, and optimization projects. With the help of data analysis, researchers may better understand traffic patterns and time signals, create predictive models, assess the success of initiatives, and make data-driven decisions to advance urban transportation systems.

REFERENCES

- [1] Jia, R., Jiang, P., Liu, L., Cui, L., & Shi, Y. (2017). Data driven congestion trends prediction of urban transportation. *IEEE Internet of Things Journal*, 5(2), 581-591.
- [2] Zhang, H., Liu, X., Ji, H., Hou, Z., & Fan, L. (2019). Multi-agent-based data-driven distributed adaptive cooperative control in urban traffic signal timing. *Energies*, 12(7), 1402.
- [3] Lei, T., Hou, Z., & Ren, Y. (2019). Data-driven model free adaptive perimeter control for multi-region urban traffic networks with route choice. *IEEE Transactions on Intelligent Transportation Systems*, 21(7), 2894-2905.
- [4] Najafi Moghaddam Gilani, V., Hosseinian, S. M., Ghasedi, M., & Nikookar, M. (2021). Data-driven urban traffic accident analysis and prediction using logit and machine learning-based pattern recognition models. *Mathematical problems in engineering*, 2021, 1-11.
- [5] Bhatia, J., Dave, R., Bhayani, H., Tanwar, S., & Nayyar, A. (2020). SDN-based real-time urban traffic analysis in VANET environment. *Computer Communications*, 149, 162-175.
- [6] Allen, M. (2020). Connected and networked driving: Smart mobility technologies, urban transportation systems, and big data-driven algorithmic decision-making. *Contemporary Readings in Law and Social Justice*, 12(2), 79-87.
- [7] Lu, H. P., Sun, Z. Y., & Qu, W. C. (2015). Big data-driven based real-time traffic flow state identification and prediction. *Discrete Dynamics in Nature and Society*, 2015.
- [8] Yo Rafique, S., Gul, S., Jan, K., & Khan, G. M. (2023). Optimized real-time parking management framework using deep learning.
- [9] Saroj, A., Roy, S., Guin, A., Hunter, M., & Fujimoto, R. (2018, December). Smart city real-time data-driven transportation simulation. In *2018 Winter Simulation Conference (WSC)* (pp. 857-868). IEEE.
- [10] Tang, J., Yang, Y., Hao, W., Liu, F., & Wang, Y. (2020). A data-driven timetable optimization of urban bus line based on multi-objective genetic algorithm. *IEEE Transactions on Intelligent Transportation Systems*, 22(4), 2417-2429.
- [11] He, L., Liu, S., & Shen, Z. J. M. (2022). Smart urban transport and logistics: A business analytics perspective. *Production and Operations Management*, 31(10), 3771-3787.
- [12] Bennett, A. (2021). Autonomous vehicle driving algorithms and smart mobility technologies in big data-driven transportation planning and engineering. *Contemporary Readings in Law and Social Justice*, 13(1), 20-29.
- [13] Fu, X., Wu, M., Tiong, R. L. K., & Zhang, L. (2023). Data-driven real-time advanced geological prediction in tunnel construction using a hybrid deep learning approach. *Automation in Construction*, 146, 104672.
- [14] Zhang, P., Zheng, J., Lin, H., Liu, C., Zhao, Z., & Li, C. (2023). Vehicle Trajectory Data Mining for Artificial Intelligence and Real-Time Traffic Information Extraction. *IEEE Transactions on Intelligent Transportation Systems*.
- [15] Mirchandani, P., & Head, L. (2001). A real-time traffic signal control system: architecture, algorithms, and analysis. *Transportation Research Part C: Emerging Technologies*, 9(6), 415-432.

- [16] Shinde, S. V., Lakshmi, S. V., Sabeenian, R. S., Bhavani, K. D., & Murthy, K. V. S. R. (2022). Traffic Optimization Algorithms in Optical Networks For Real Time Traffic Analysis. *Optik*, 170418.
- [17] Sadiqa, J., & Yung-Cheol, S. Z. B. (2022). Signal Traffic Optimization Using Control Algorithm in Urban Traffic Framework. *Turkish Journal of Computer and Mathematics Education (TURCOMAT)*, 13(2), 1018-1034.