

## Voltage Sag Mitigation Using DTATCOM

Atta Ur Rehman\*, Muhammad Saad<sup>1</sup>, Imtiaz Ahmad<sup>2</sup>, Muhammad Ismail<sup>2</sup>, Mian Muhammad Amir Ayaz<sup>3</sup>, Ihteshamul Haq<sup>3</sup>

<sup>1</sup> Department of Electrical Engineering, University of Engineering and Technology, Mardan 23200, Pakistan

<sup>2</sup> Engineering Management department, University of Engineering and Technology Taxila, 47050, Pakistan

<sup>3</sup> National Power Control Center Islamabad Npcc, Pakistan.

<sup>4</sup> Department of Electrical Engineering, University of Engineering and Technology, Mardan 23200, Pakistan

\*([atta4889@gmail.com](mailto:atta4889@gmail.com))

(Received: 25 August 2023, Accepted: 29 August 2023)

(1st International Conference on Recent and Innovative Results in Engineering and Technology ICRIRET 2023, August 16-18, 2023)

**ATIF/REFERENCE:** Rehman, A. U., Saad, M., Ahmad, I., Ismail, M., Ayaz, M. M. A. & Haq, I. (2023). Voltage Sag Mitigation Using DTATCOM, *International Journal of Advanced Natural Sciences and Engineering Researches*, 7(7), 269-274.

**Abstract** – Voltage sag is the most important power quality problems faced by many industries and utilities. In developing countries like India, in distribution network due to increasing number of nonlinear loads that injects harmonics in the system results in various types of power quality problems. Thus, for overcoming reactive power burden and to lessen power quality issues such as voltage dip, voltage swell and flicker as well as adverse harmful effects being caused by various types of load, it becomes crucial to take positive steps in this direction. For this different types of FACTS devices can be used such as SVC, DVR, TCSC, STATCOM, UPFC, and DSTATCOM. This paper discusses the detrimental effects of excessive reactive power consumption by maximum AC loads on power quality within a power system. To address this issue, compensating devices like DSTATCOM are introduced. These devices are designed to effectively manage the flow of reactive power in distribution system. This paper provides a comprehensive background on compensating devices and their power electronic applications, along with a detailed analysis of DSTATCOM modeling for effective compensation. This paper extensively covers the modeling and simulation of diverse control strategies in MATLAB Simulink with the assistance of simpower systems toolboxes. The primary focus is on DSTATCOM and its performance is rigorously analyzed under varying load condition, including resistive, inductive, and capacitive loads.

**Keywords** – DSTATCOM, Power Quality, Adjustable Speed Drives, Programmable Logic Controller, PIC Microcontroller,

### I. INTRODUCTION

In present times, despite the relatively dependable power generation, power quality (PQ) issues persist, posing challenges. The growing demand for nonlinear loads in distribution lines has further compounded these PQ problems, making them a significant concern. The distribution system currently faces a range of PQ issues including voltage sag, swell, and flicker [1]. Voltage sag is one

of the most complex problems faced by industrial and commercial customers [2], and it negatively affects the behaviour of induction motors, adjustable speed drives (ASD), process control systems, and computers [3]. The most significant power quality issue that many industries and utilities deal with is voltage sag. More than 80% of the power quality (PQ) issues in power systems are caused by it. Voltage sag is defined as a decrease in

RMS value in AC voltage at power frequency, lasting from a half cycle to a few seconds. [4]. Sensitive equipment utilized in contemporary industrial plants, such as process controls, programmable logic controllers (PLC), adjustable speed drives (ASD), and robots, cannot tolerate voltage sags. According to reports, industrial equipment like PLCs and ASDs have voltage sags of roughly 10% while high intensity discharge lamps used for industrial illumination experience voltage sags of 20% [4-5]. A voltage sag is characterized by a sudden drop in the supplied voltage from 90% to 10% of its nominal value [6].

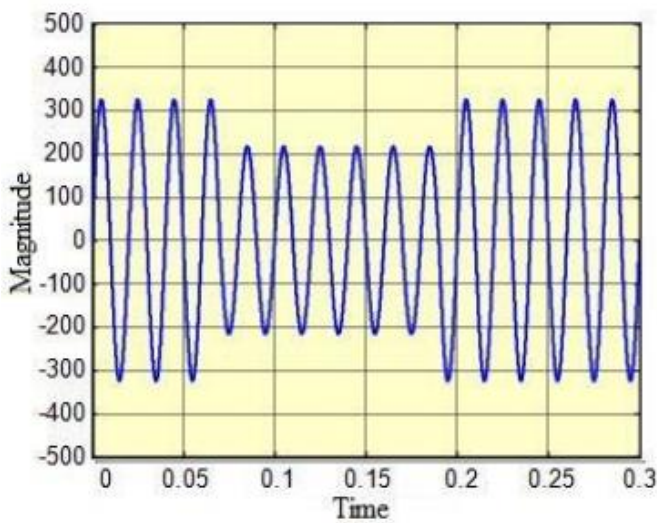

Fig. 1 Voltage sag

Sag typically lasts between 10ms to 1 minute. Such circumstances make electricity loads susceptible to voltage sag. Because of this, the focus of our research will be on using specialized devices like D STATCOM, which is a way to reduce voltage sags and enhance power quality.

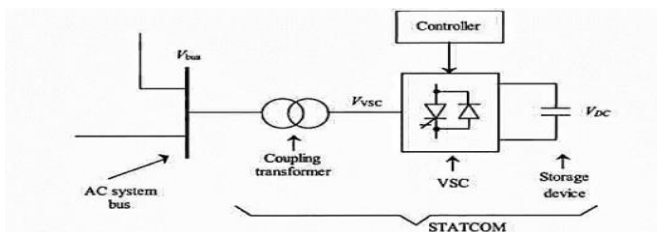

Fig. 2 The “D STATCOM” Layout

Power system-related issues encompass a wide array of problems, including voltage swell, voltage sag, harmonics, and various types of disturbances [7]. To address the voltage sag problem, a statcom network was designed, combining PWM circuit and the dq0 analytical procedure [8]. This configuration

effectively maintains the voltage sag. For controlling the output of the DSTATCOM, “PI controller” and PWM are employed to accelerate the activation signals for the switching devices [9]. The utilization of a PIC Microcontroller contributes to swift mitigation of a power quality problems, leading to substantial improvement in power quality concerns [10].

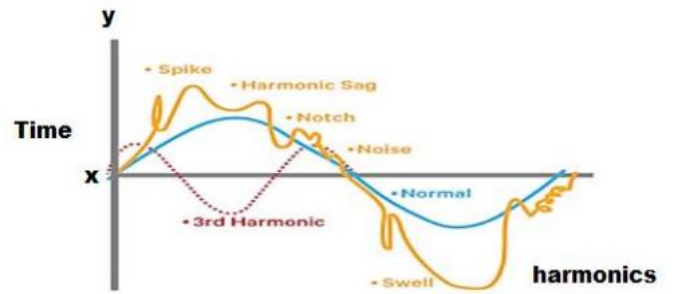

Fig. 3 Common power quality problem

The hardware parts with the rectified supply are shown in the diagram below. This figure has a rectifier added along with the source. We are aware that the inductor and capacitor are the two most crucial parts employed in any "D STATCOM". Since the inductor cannot operate on a dc source, we are just using the capacitor in this prototype as our hardware for working on dc voltages. The inductor will be harmed if we add it to the dc supply. The hardware is described in more detail in the diagram below.

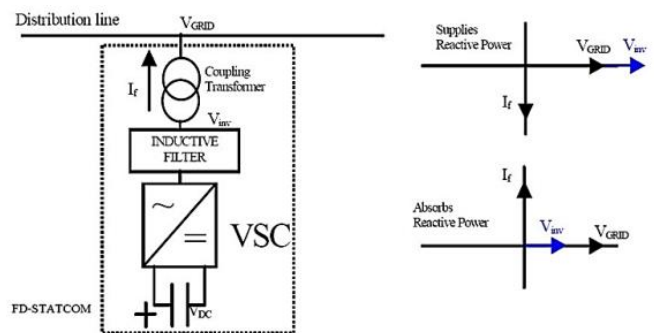

Fig. 4 The schematic representation of D STATCOM

Different Various technologies, such as STATCOM and SVC, are employed for voltage mitigation, but they do come with certain limitations. Both STATCOM and SVC require connection to the main grid to facilitate flexible AC transmission. STATCOM components must be connected in parallel with the grid station for integration. We can

only "D STATCOM" can be used to improve the voltage quality in homes; otherwise, all other methods are typically employed in the main distributed lines to change the rules and standards of the voltages that are communicated to customers. Improvements in voltage regulation for home use are the fundamental remedies for these restrictions. To stabilize the voltage level and enhance the effectiveness of the voltage regulation, we advise using filtering capacitors and the "d statcom".

system, we combine a stepdown transformer and a bridge rectifier. This configuration converts the input AC power into pure DC with the aid of a filtering capacitor. The basic hardware diagram is illustrated in Figure 7 below.

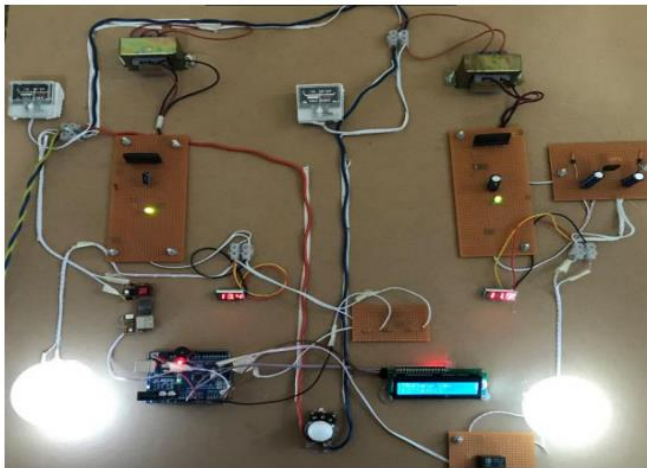

Fig.5 The Prototype Hardware model

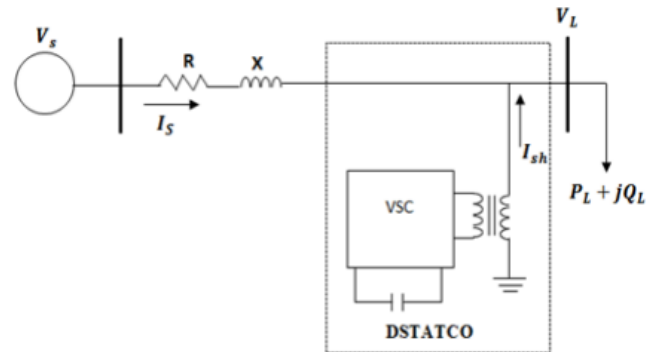

Fig. 7 "D STATCOM" basic Diagram

## II. HARDWARE SPECIFICATION

Table 1 The Hardware Specifications

NAME OF HARDWARE	STEP DOWN TRANSFORMER
Turn ratio	$N_p/N_s=12/220$ $N_p/N_s=3/55$ $N_p/N_s= 3:55$ $N_p/N_s=1:55/3$ $N_p/N_s=1:18.3$
Input voltages	220volts
Output voltages	12volts
Current ratings	1Amphere
Connection type	Parallel
Operating Frequency	50Hz
Efficiency	94%
<b>Name of Hardware</b>	<b>Bridge Rectifier</b>
Input voltages	12volt AC
Output voltages	12volts DC
Current Ratings	1 Ampere
Connection type	parallel
<b>Name of Hardware</b>	<b>Arduino</b>
Model	UNO R3
At mega	328p
Input voltages	5volt DC
Purpose of use	Detection of sag
LCD display	Enable
<b>Name of Hardware</b>	<b>LCD</b>
Model	16*2
Input voltages	5volts Dc
Purpose of use	To display results
Contrast	Enable

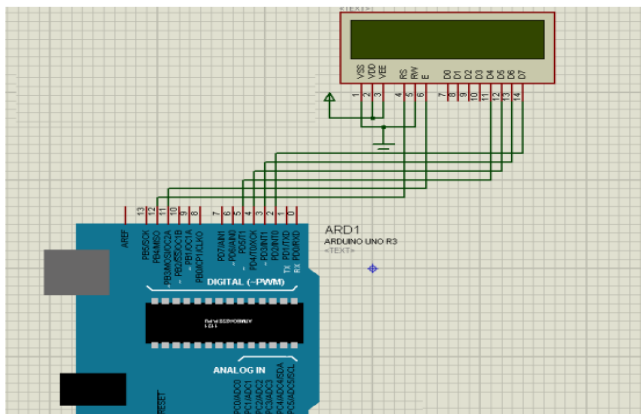

Fig. 6 simulation diagram

The prototype hardware's fundamental approach is to stabilize the voltage level during sag occurrences. To achieve this, a set of capacitor is employed to store charge and boost voltages when input voltages are low. In the implementation of this hardware, the key components are the capacitor and the inductor, although, for this particular setup, only the capacitor is used in parallel to reduce voltage drop.

For the hardware implementation, we exclusively use the DC system in the prototype. The use of AC is avoided due to safety hazards and for simplifying the implementation process. To create the DC



<b>Name of Hardware</b>	<b>Relay</b>
Input Voltages	12-24 VDC/VAC
Type	Electro Magnet
Operation Type	Automatic
Purpose of use	Automation
<b>Name of Hardware</b>	<b>Voltmeter</b>
VAC Input voltages	0-300 VAC
Type	Analogue
Current ratings	20Ampere
Connection type	Parallel
<b>Name of Hardware</b>	<b>Capacitors</b>
capacitance	25uf
Type	Electrolytic
Voltages	35 volts
<b>Name of Hardware</b>	<b>Voltage Regulator</b>
Input voltages	I 220 -240 VAC
Current Ratings	2 amperes

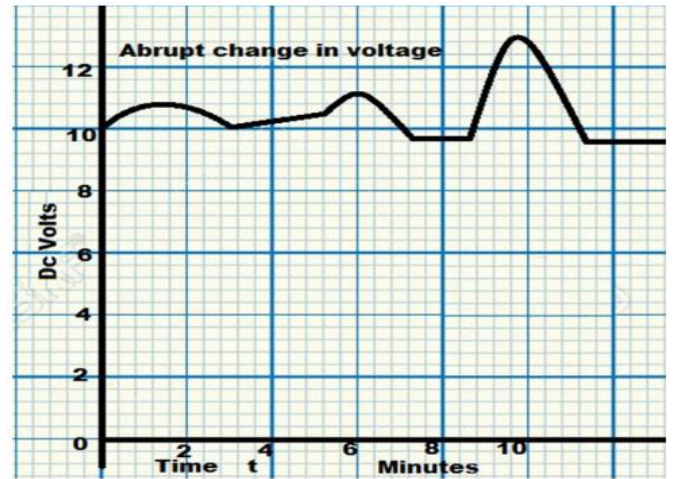

Fig. 9 The voltage sag Graph Without DSTATCOM

### III. RESULT AND DISCUSSION

When the network sags, the hardware reacts by supplying the necessary voltage across the load to keep the voltage constant. The compensated sag is shown in Figure 8.

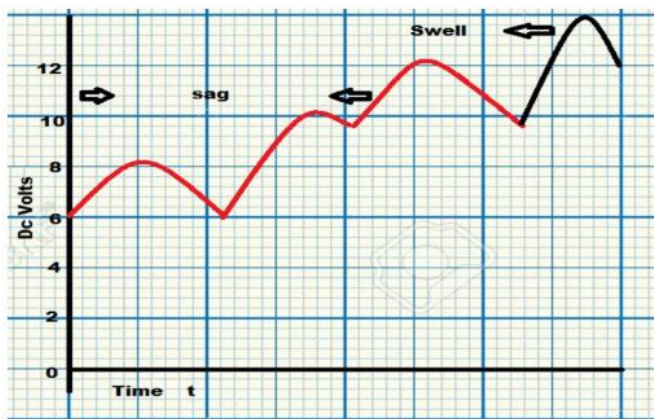

Fig. 8 The voltage sag and the Swell graph

The above graph shows the sag and the swell of the system the graph below shows the change in the voltage level without DSTATCOM.

The graph in the previous figure illustrates how the voltage regulation has changed since the first graph. The DSTATCOM smooths the hardware's output voltage, which is seen in the aforementioned Figure 10.

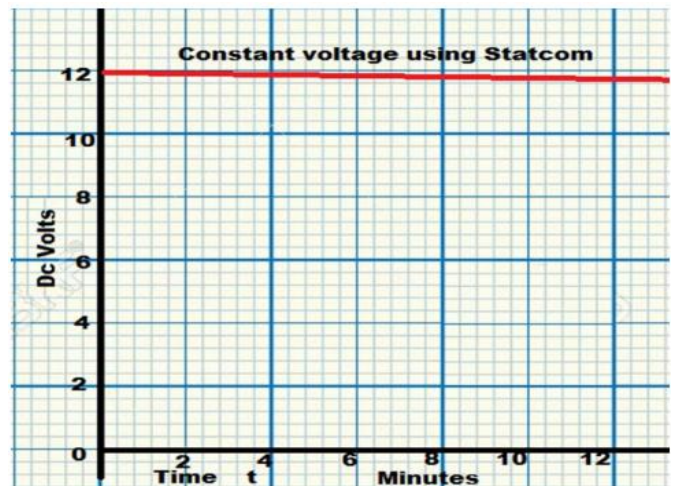

Fig. 10 The voltage Regulation Graph with the DSTATCOM

#### A. RESULT OF OUR DEMO MODEL

The hardware results of our model have surpassed our expectations. The voltage sag limit of our designed model spans from 10 to 90 percent, indicating that if the incoming voltage is 220volts AC, the hardware can effortlessly compensate for voltage variations above 100 volts AC.

Table 2 The Hardware Results of the D STATCOM.

Hardware name	"D STATCOM"
Sag compensation ratio	90%
Input voltages	240V-110V
Overall efficiency	90percent
Protection mode	Enables below 100 volts
Series injection transformer	Enable
Sensitive load protection	Enable
Short Circuit protection	Enable
Over current Protection	Enable
Remote Control operation	Enable
Output Voltages	12volts DC constant
Maximum loading capacity	4KVA ,10 amperes(prototype)

**B. SOFTWARE RESULTS**

The "D STATCOM" is implemented with a "PWM" programmable device to address the system sag. In the event of disruptions, the goal is to control and maintain a steady voltage across the delicate load. There is no need to measure the KVA because the rms voltage at load is detected using "PWM".

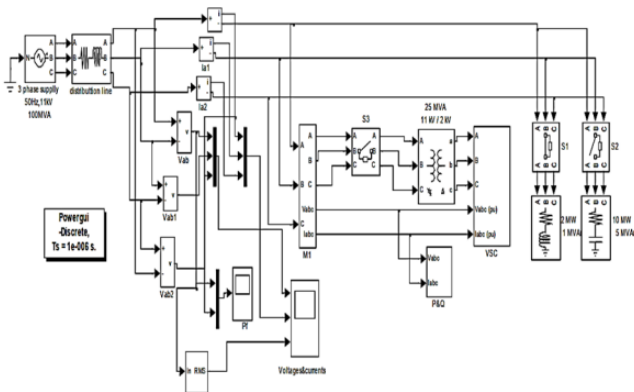

Fig. 11 MATLAB Simulink of D STATCOM with 11kv line  
The simulation process for sag detection work on the following algorithm

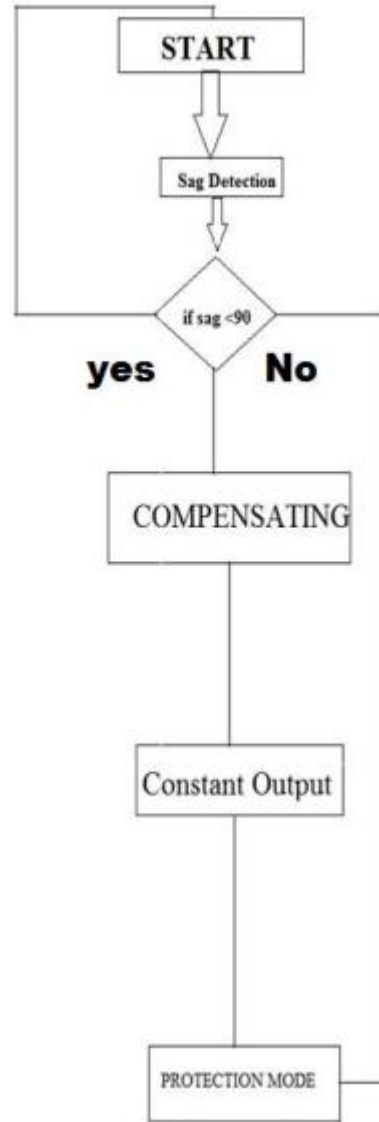

Fig. 12 Flow Chart

The "D STATCOM" control model created in "MATLAB/SIMULINK" is shown in Figure 13 below. The controlling model generates a voltage angle control by first obtaining and analyzing an error signal at the load point. In order to reduce the error to zero, the "PI controller" processes the error signal and generates the necessary angle. The flow chart "p.f" for the circuit's power flow is shown in the image above. Other software outputs, including "MATLAB Simulink," are provided below for further demonstration.

